

en Ultrasound Surgical Equipment

Please read all information carefully.

WARNING: Safe and effective utilization of ultrasonic surgery equipment rely on the comprehension of the operator. To ensure the safety and effectiveness of this equipment, it is necessary to read, understand and observe the operating instruction supplied with the equipment.

WARNING: This equipment is only designed for medical surgery procedures.

WARNING: Do not use this equipment in places with inflammable anesthetic gases mixed with air, oxygen, or nitrogen oxide. Sparks generated by collision with other metal apparatuses may ignite inflammable gases.

Chapter I – Overview

The user must read those texts carefully before using the product. The content aims to explain operating processes that needs attention, operations that may cause abnormalities, and hazards that may cause damage to the product or to person. In case of any abnormal situation, follow specified instructions to avoid bodily harm or damage to the equipment. The manufacturer does not assume any liability for safety, performance warranty compromise or extended maintenance due failure to follow these instructions.

Intended Use

This instrument is intended for soft tissue incisions when bleeding control and minimal thermal injury are desired.

Indications

This instrument is indicated for soft tissue incisions when bleeding control and minimal thermal injury are desired. This device can be used as an adjunct to or substitute for electrosurgery, lasers, and steel shears for cutting and/or coagulating tissue in open surgeries or endoscopic surgeries, In general, pediatric, gynecologic, urologic, thoracic, and sealing and transection of lymphatic vessels.

Intended User

This instrument is intended for use by healthcare professionals for surgical applications.

Intended Use Environment

This device is intended to be used in a hospital.

Intended patient population:

Patients aged 3 and older who need surgery in which soft tissue incisions with bleeding control and minimal thermal injury are required.

Clinical Benefit:

- Shorter operative time;
- Less intraoperative blood loss;

- Less thermal injury.

Contraindications

The instruments are not indicated for incising of bones.

The instruments are not intended for contraceptive tubal occlusion.

Chapter II - Composition and Operating Principles of Ultrasound Surgical Equipment

Section I Equipment components

Table 1 Components of Ultrasound Surgical Equipment

Model	Composition	
	Part Name	Model No.
Ultrasound Surgical Equipment	Generator of Ultrasound Surgical Equipment	CSUS8000
	Transducer of Ultrasound Surgical Equipment	TRA6
	Foot Switch of Ultrasound Surgical Equipment	FSW2

The generator is compatible with shears which manufactured by Reach Surgical, Inc. The shears instruments are not included in this packaging and must be purchased separately. For shears details refer to the shears manual.

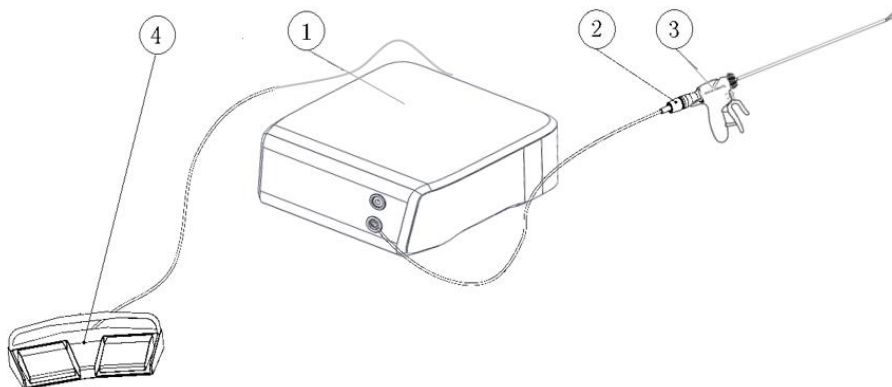

Figure 1 Composition Drawing of the Ultrasound Surgical Equipment

1. Generator. 2. Transducer. 3. Shear. 4. Foot Switch.

1. Generator (CSUS8000)

The Generator provides operation interface display, device condition monitoring, ATT function and I/O control. Different levels provide corresponding energy outputs by the control of the Shear and the Foot Switch.

Definition of ATT function: The system can automatically adjust the ultrasonic output energy according to the feedback from different tissues.

2. The Transducer (please refer to Transducer operation manual for more information) is designed to convert electrical energy from a compatible Generator to mechanical motion for the instrument blades. This Transducer is intended for use with a compatible Generator.

- The Transducer is attached to a cord which connects to the front of the Generator.
- The Transducer is re-usable instrument with limited-service life.
- The Transducer is packaged non-sterile and must be sterilized per instructions prior to use.

3. Shear (please refer to Shears operation manual for more information)

Note: In this manual, Disposable Ultrasonic Scalpels and Disposable Ultrasonic Shears will be displayed as 'Shear' on the generator screen.

The ultrasonic vibration is transferred from the Transducer to the Shear and is used for the haemostatic cutting and/or coagulation of the tissue.

Please note that the mechanical vibration coming from the Transducer is magnified by the amplitude transformer. Vibration is microscopic and invisible to the naked eye. Avoid touching unintended targets with the tip during procedure.

4. Foot Switch

The Foot Switch is used for switching on/off the output of ultrasonic energy.

5. System mode and Power level

Different system mode interface will be displayed when the generator is connected with different Shears.

When connected to shear without Advanced Hemostasis function, the Generator provides two modes of output: VAR and FULL. VAR power can be set by user from 1 to 5 by pressing buttons on the interface display. FULL power is always maintained at level 5.

When connected to Shears with Advanced Hemostasis function, the Generator provides two modes of output: VAR and ADVANCED. VAR power can be set by user from 1 to 5 by pressing buttons on the interface display. The default level remains at level 5. ADVANCED means advanced hemostasis function is used for fast tissue cutting. Lower power is used for better haemostasis. The energy transmitted to the tissue and the tissue effect produced depend on many factors, including the power level, Shear shape, Shear performance, clamping force (if applicable), tissue tension, tissue type, pathology, and surgery approach.

Section II Operating Instruction

(Figure 2-1 Front panel)

1. Display/Touch Screen

Displays system information and serves as interface for adjusting controls and settings.

2. Transducer socket

The socket on the lower right corner, which is used to connect the Transducer to the Generator.

3. Standby Button

Press the Standby Button to turn on the Generator. Long press to shut down.

(Figure 2-2 Rear panel)

4. Vents

5. Equipment expansion interface

Used for equipment function expansion and maintenance.

6. Potential Equalization

If the user cannot ensure that the power socket has been safely grounded, the user can connect the protected earth through this port.

7. Power socket

The socket is used to connect the Power Cord to the Generator.

8. Foot Switch socket

This is the circular socket is shown in the figure 2-2, which can be connected to the Foot Switch by the user.

9. Mounting hole

Section III Unpacking notice

Components of the Ultrasound Surgical Equipment are purchased separately. Upon receipt of purchased components, please check whether there are visible transportation damages. In case of any damage, please contact the Reach Surgical, Inc or the local agent.

Components include the followed (please see Chapter IX - Technical Conditions of the Equipment):

Generator (CSUS8000) - including Generator, Power Cord, and user's manual.

Transducer (TRA6) - including transducer with cable.

Foot Switch (FSW2) - including Foot Switch and detachable cable assembly.

Note: User's manual includes the guide to fault detection and elimination.

Chapter III - Installation and Operation of Equipment

WARNING: To reduce the hazard of interference, Electrosurgical equipment and the Ultrasound Surgical Equipment should be connected to separate power supply circuits.

WARNING: To avoid injury to the user or patient in case of accidental activation, if the Generator of Ultrasound Surgical Equipment is damaged or it is suspected that it has fallen or that water has got into it, a biomedical evaluation must be carried out before deciding whether it can be used.

Section I Turn on the Equipment

I. Before installation, make sure the Power Cord is not connected to the Generator.

II. Place the Generator on flat surface.

WARNING: The Generator must be operated under the specified environmental conditions. For requirements, please see Chapter IX - Technical Conditions of the Equipment.

III. Connect the Power Cord to the AC input socket on the rear panel of the Generator. At this time, the system is not started, and the Standby lamp is in the breathing flashing state.

WARNING: Please keep the generator and the power cord in a position that can be easily separated to ensure that the power supply is disconnected in time in case of emergency.

WARNING: Ensure power supply meets requirements of the Generator (see Chapter IX - Technical Conditions of the Equipment). Improper connection of the power supply may damage the Generator or cause shock or fire hazard.

IV. Connect the Foot Switch to the Foot Switch socket on the rear panel of the Generator.

- Ensure that the connector socket is dry and clean.
- Avoid introduction of liquid as it may cause accidental activation.

WARNING: Always keep the shears away from the people before activation to avoid injury to the user, other apparatuses, or other objects.

V. Press the Standby Button to turn on the Generator. The Generator will start initialization sequence.

Please refer to the description in Section II of Chapter III for displayed information during initialization sequence.

VI. Ensure that the Transducer connector is dry and clean, then securely connect the Transducer cable to the socket on the front panel.

VII. Connect the Shear to the Transducer in accordance with the operating instruction.

If the initialization sequence is different from that described above, please contact certified maintenance personnel according to procedures of the hospital. The expected location of the equipment will be arranged by professional surgical staff in the hospital.

VIII. After completion of the initialization sequence, the Generator will enter standby mode. If error is detected, an error code will be displayed on the LCD screen and alert sound will be heard. Refer to Chapter IV for more details.

IX. System mode and Power level: the default power level of the Generator is 3 (VAR) and 5(FULL). To adjust the VAR power level, press the UP/DOWN arrows on the left of the liquid crystal screen to change it from 1 to 5. Set the power level according to the preference of the surgeon and/or the recommendation of the Shear operating instruction (for more details, please see the power level section of Chapter II).

X. Sound: The Generator uses different sounds to indicate activation power level.

Section II Equipment Operation

Important note: The user's manual of the Ultrasound Surgical Equipment includes the operation instructions for the CSUS8000 Generator and the Foot Switch (seen Chapter IX - Technical Conditions of the Equipment). This manual is not a reference of surgical techniques.

Note: Before using the equipment, it is advised to read the instructions for the Transducer and the Shearas well.

After installation, the equipment can now be operated.

WARNING: To avoid injury to the user or patient during equipment inspection, use caution to keep the distal end of the instrument away from other apparatuses, the surgical drape, the patient or other objects. During inspection, safety measures taken in the presence of vapors (according to procedures and regulations of hospital) should be implemented.

The operation of the system is divided into three parts: system startup and identification of the Transducer and the Shear, testing of the Transducer and the Shear and system setting.

1. Initialization sequence and identification of the Transducer and the Shear:

After pressing the Standby Button, the following image will be displayed:

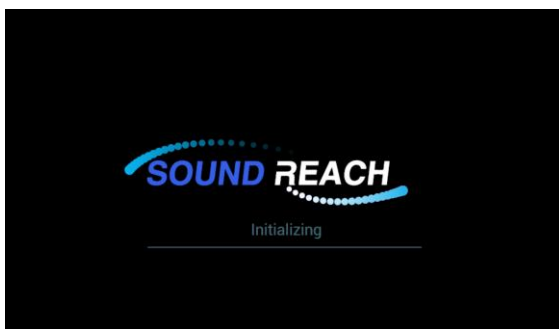

If no Transducer or Shear is connected to the Generator, or if they are connected incorrectly, the following image will be displayed:

Note: To change the language, click the icon on the top left corner and refer to Chapter III, Section II for detailed steps.



If the Transducer and the Shear is correctly connected to the Generator, the following image will be displayed:

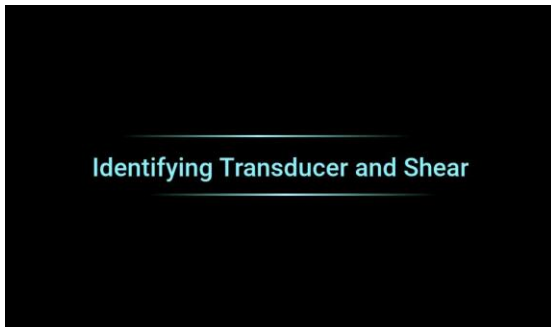

When the Transducer and the Shear are connected and identified correctly, the following image will be displayed:

Note: To change the language, click the icon on the top left corner and refer to Chapter III, Section II for detailed steps.

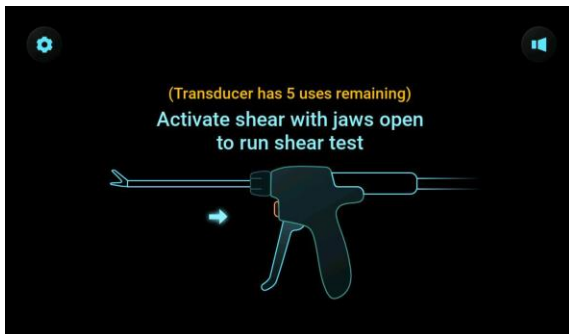

Note: if the remaining use of the Transducer is less than 10, the following image will be displayed. Please pay attention to the number as the Transducer needs to be replaced when the number is zero:



When connected to Shears with Advanced Hemostasis function, If the shears has been used before, the following image will be displayed:

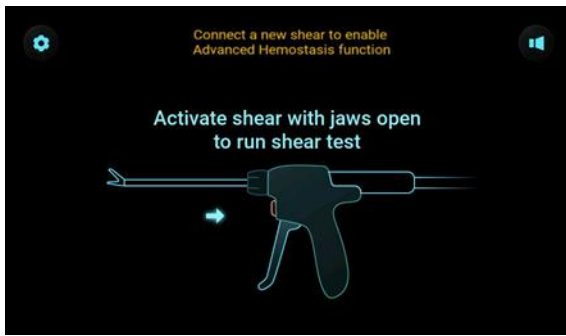

2. Testing of the Transducer and the Shear:

When the identification of the Transducer and the Shear is completed and 'Activate Shear with jaws open to run Shear test' will be displayed, press any button on the shear , and the following image will be displayed:

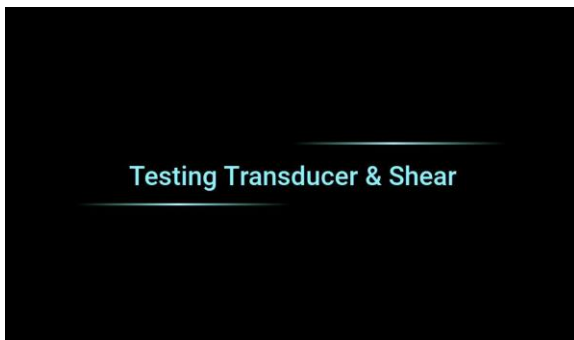

The following image will be displayed when the test failed:

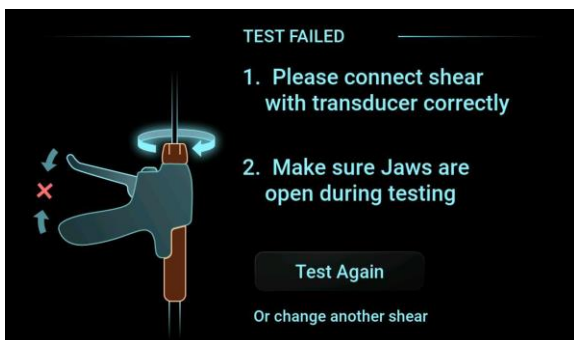

The following image will be displayed when the test passed, and automatically switch to the next image:

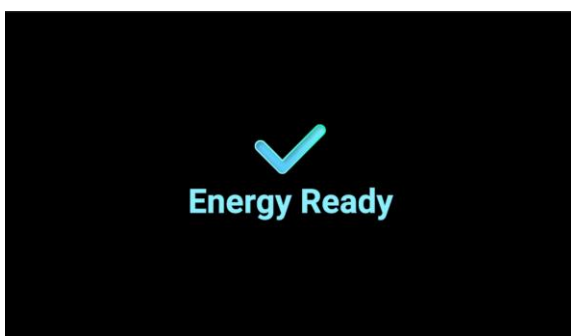

When connected to Shears without Advanced Hemostasis function, the following working state image will be displayed:



When connected to Shears with Advanced Hemostasis function, the following working state image will be displayed:



An output mode will be highlighted when a corresponding button is pressed.

3. System settings:

Click the setting icon in the top left corner of the screen, and the system setting items are as follows:



Click the Language icon and then click on a language to change the displayed language.



Click the 'Enable / Disable Hand/ Foot Control' and then click on the option to change the options.



Click the 'Advanced Setting' and then click on the option to change the options.

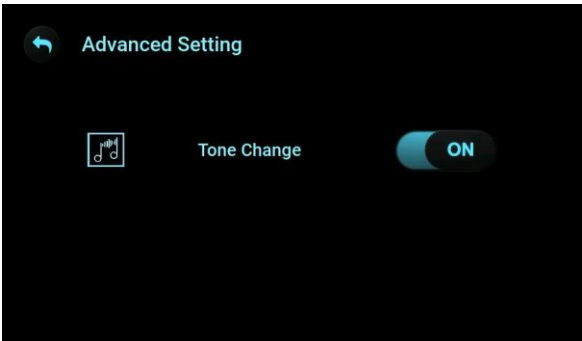

Click the system information item to display the following interface:

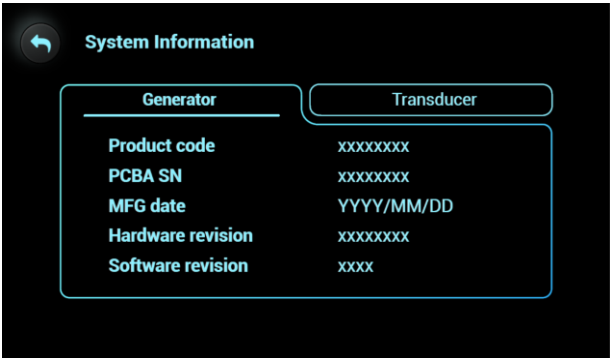

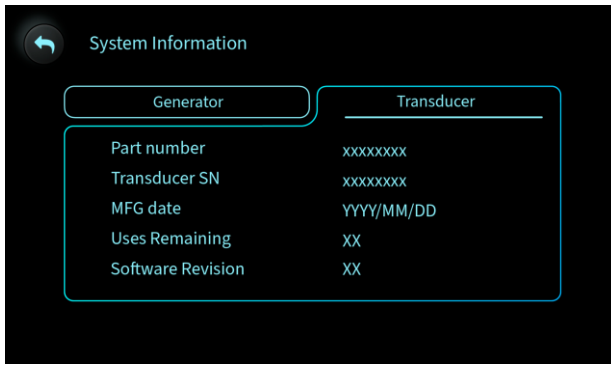

Click the diagnosis item and the following interface will appear:

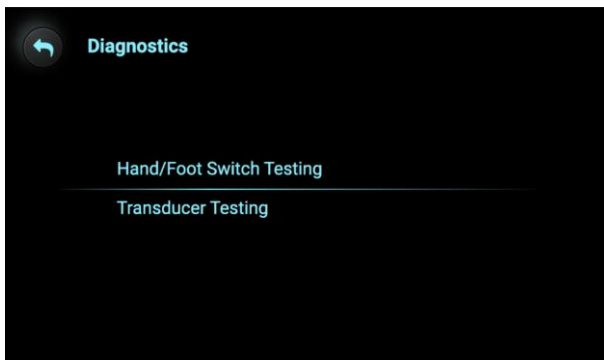

Click the 'Hand/ Foot Switch Testing' item, and the following interface appears:

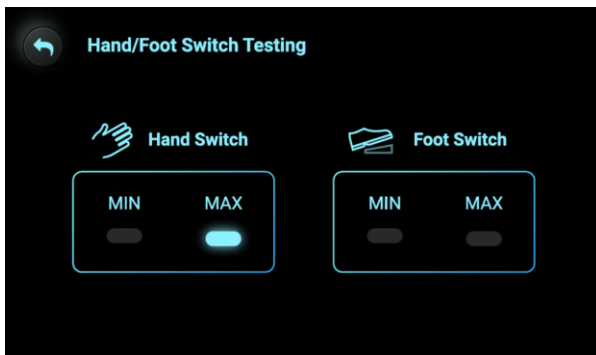

Click the Transducer testing and the following interface will appear:

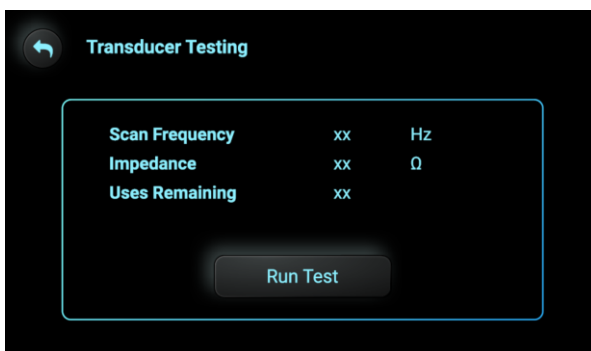

Cancel

Press the 'Return' icon on top left corner of screen to leave the system settings and return to the system standby mode.

Section III Turn off the Generator

- I. Press the Standby Button of the Generator and pull the Power Cord out of the outlet socket.
- II. Disconnect the Transducer and the Shear and handle them according to their operating instructions.
- III. Clean the Generator, Foot Switch and Transducer according to the procedures as stated in Chapter V Cleaning

Chapter IV - Troubleshooting

The Generator has a series of alert signals and error codes to help to recognize and detect faults of elements and components. These signals and codes are intended to help clinical judgment and observation instead of replacing them.

Section I Audible indicator and alert

Working State	Sound Type	Possible cause and corrective measures
Initial State	Normal working sound	/
	Abnormal working sound	Fault of hardware. Contact the manufacturer for repair.
Activating State	Max Level working sound	/
	Min Level working sound	/
	Abnormal working sound	1) The Shear has contacted or grasped too much tissue. Reduce the amount of tissue in contact with the shear. If there is still a continuous sound, remove the tissues gathering round the end of the Shear end effectors carefully. 2) Transducer and/or Shear fault.
	ADVANCED sound	/

	ATT sound	/
--	-----------	---

Section II Error Code

The Generator will recognize faults in two ways: warning and system error. When a fault is recognized, an alert sound will be given, an alert indication signal will appear on the control panel of the Generator, and the problem will be displayed on the liquid crystal screen. Resolve the problem according to solutions given as follows (or try troubleshooting).

The Generator will identify two specific faults: warning and system error. When a fault is identified, the system sends out an alert sound, the alert indication signal appears on the Generator control panel, and the corresponding fault code will be displayed on the LCD screen. Follow the methods given below (or in the Troubleshooting Guide) to solve the problem.

Table of fault codes and messages

Error code	Corresponding fault message
Warning	Please connect Shear with Transducer correctly
Warning	Make sure jaws are open while testing
Warning	Shear Error Detected
Warning	Transducer has 0 uses remaining
Warning	Please activate only one button at a time
Warning	Please release pressure on shear
System Error	System Error
System Error	Self-check Failed

1. Make sure that the Transducer cable has been inserted completely in the correct orientation.
2. The Shear may have been tightened incorrectly or some tissues may have gathered around the end of the Shear. Tighten the Shear and remove the tissues gathering round the end of the Shear casing carefully. (If a test is started before the operation, make sure that the Shear points to the air. If ultrasonic shears shear s are used, before the test, make sure that the clamping jaw is open and not in contact with any object).
3. Replace the Transducer or Shear
4. Enter to the equipment working mode.

Note: The Transducer will be unable to work properly if its temperature exceeds the specified value.

In this case, use another Transducer to recover immediately or determine cause of error and optional recovery

methods according to the following steps.

The Transducer is still warm because it has just gone through steam sterilization. Let the Transducer cool down at room temperature for at least 45 minutes.

This method can also be used if the Transducer becomes hot after extended operation at high power.

If there is no evidence of Transducer overheating, and it seems that the problem cannot be resolved, contact maintenance representatives of the manufacturer.

Other than fuses, there are no operator-serviceable parts in the Generator. For replacement or service, contact the service personnel trained and authorized by Reach Surgical, Inc. or your local representative.

Any maintenance and upgrade of the Generator must be carried out by service personnel trained and authorized by Reach Surgical, Inc.

The following incidents may bring cybersecurity threats:

1. Forced access of any non-related products for the Ultrasound Surgical Equipment of Reach Surgical, Inc.
2. Any unauthorized network communication with the Ultrasound Surgical Equipment of Reach Surgical, Inc.
3. Any firmware or software upgrades not authorized by Reach Surgical, Inc.

If any of the above incident occur, please contact the sales representative of Reach Surgical, Inc. or directly contact the Reach Surgical, Inc. with Reachquality@reachsurgical.com.

Chapter V – Cleaning

Section I Cleaning the Generator

- Clean the Generator according to hospital procedures or regulations. Before cleaning, disconnect the main power supply of the Generator and pull the Power Cord out of output unit.

<p>WARNING: Cleaning may damage the Generator and cause shock or fire hazard by spilling or splashing liquid over or into the Generator or immersing the Generator into liquid.</p>
--

Implement cleaning according to the following steps

1. Prepare a neutral PH detergent or neutral PH enzyme detergent according to the instruction of the detergent manufacturer.
2. Wipe all the surfaces (including the Generator screen) manually with a clean, soft cloth soaked with a small amount of cleaning solution.
3. Wipe with a clean, soft cloth soaked with warm tap water.
4. Wipe with a clean, soft cloth.

Section II Cleaning the Foot Switch

Clean the Foot Switch and cable after use according to the following procedure:

1. Disconnect the Foot Switch from the Generator.
2. Prepare a neutral PH enzyme detergent according to the instruction of the manufacturer.
3. Connect the cable with the Foot Switch securely and immerse them in the cleaning solution for 2 minutes.

Note: To prevent accidental activation, the Foot Switch cable used to connect the Generator should be completely dry.

4. After immersion, scrub the Foot Switch and cable manually with a soft bristle brush in the cleaning solution.
5. Rinse the Foot Switch and cable thoroughly with warm tap water for at least 1 minute

During rinsing, the cable and the Foot Switch should be securely connected.

6. Wipe all the surfaces with a clean, soft cloth

WARNING: Do not use ultrasonic cleaning machine to clean the Foot Switch.

WARNING: To avoid damaging the Generator, do not switch on its power supply before the AC power cable has been connected to the Generator. Before assembly, make sure that all the connections are dry.

Chapter VI - Safety and Functional Tests

WARNING: To avoid possible electrical shock hazard, do not open the Generator casing without authorization. Any maintenance and upgrade of the apparatus must be carried out by service personnel trained and authorized by Reach Surgical, Inc.

WARNING: To avoid shock or burn hazard to the patient and medical personnel or damage to the equipment or other apparatuses, it is necessary to gain an insight into the principles and techniques of laser surgery, electro surgery and ultrasonic surgery. Make sure that the electrical insulation or grounding is kept undamaged. Do not immerse electrosurgical units in liquid unless required by the design or indicated on the label.

WARNING: To avoid electric shock risk, this equipment must only be connected to a supply main with protective earth.

WARNING: To avoid injury to the user or patient, during equipment inspection, make sure to keep the Shearaway from other apparatuses, the surgical drape, the patient or other objects. During equipment inspection, the safety measures taken in the presence of vapors (according to the procedures and regulations of the hospital) should be implemented.

Implement safety and functions tests of the Transducer, Generator, and Foot Switch according to procedures and regulations of hospitals. For safety and function tests of other components used by multiple patients, please see the operating instruction of each component.

Section I Safety Test

Generator: Leakage current test should be implemented by certified hospital technicians.

Foot Switch: Check the pedal, cable connector and cable to see if they are cracked or otherwise damaged. Replace if damaged.

Other components: Check according to the operating instruction.

Section II Functional Test

1. Prepare the complete set of Shear and connect the Transducer according to description of Chapter III - Installation and Operation of the Equipment.
2. Check if it is possible to enter the working state.
3. Check to see if VAR power Level 3 and FULL power Level 5 are displayed.
4. Press the power increase and decrease button to make sure that the VAR power level can be changed from levels 1 to 5.
5. Switch off the power supply of the Generator. Wait for 5 seconds, and then switch on the power supply of the Generator. Wait for 15 seconds.
6. while entering the working state, check if VAR powers Level 3 and FULL power Level 5 are displayed. Check to see if the Generator is activated according to the requirements. Hold the Transducer in such a way that its far end points to the air and step on the FULL pedal of the Foot Switch. Check the FULL power level indicator on screen to see if it flashes and if a sound indicating FULL activation can be heard.
7. Hold the Transducer in such a way that its far end points to the air and step on the VAR pedal of the Foot Switch. Check the VAR power level indicator on the screen to see if it flashes and if a sound indicating VAR activation can be heard.

WARNING: To avoid user or patient injury in the event that accidental activation occurs, the Shear should not be in contact with patient, drapes or flammable materials while not in use.

Chapter VII - Warnings and Identification

WARNING: Only personnel who are certified and familiar with minimally invasive technique may perform minimally invasive surgery. Before carrying out any minimally invasive surgery, consult medical literature related to minimally invasive technique, complication, and surgical risk.

WARNING: Just like all energy sources (high frequency, laser or ultrasonic), the possible carcinogenic or infection hazard caused by the by-products of the tissues, such as fume and mist, should be taken into consideration. In open and abdominal surgeries, proper protective measures should be taken, such as wearing goggles and filter-type respirators and using effective fume extractors.

WARNING: After this apparatus has been used, check if the tissue has stopped bleeding. If not, corresponding measure should be taken.

WARNING: Use of products produced or distributed by companies except the Reach Surgical, Inc. may be incompatible with CSUS Ultrasonic shear. Using these products may lead to unexpected results and cause injury to the user or patient.

WARNING: Some components (such as Transducer) of CSUS Ultrasonic Shear may not have been sterilized before leaving the factory. Before installing the equipment, sterilize the product according to the requirements. For cleaning and sterilization notices, please see the related instructions.

WARNING: To avoid diverting the transfer of ultrasonic energy, do not exert too much pressure on the Shear handle.

WARNING: Spilling or splashing liquid over or into the Generator or immersing the Generator in liquid may damage the Generator and cause shock or fire hazard.

WARNING: INTERCONNECTIONS CONDITIONS require the APPLIED PARTS of other ME EQUIPMENT used within the CONFIGURATION FOR ENDOSCOPIC APPLICATION to be TYPE BF APPLIED PARTS or TYPE CF APPLIED PARTS

WARNING: when ENERGIZED ENDOSCOPES are used with ENERGIZED ENDOTHERAPY DEVICES, Effects such as interference produced by the operation of high-frequency surgical equipment may adversely impact the operation of other electronic medical equipment such as monitors and imaging systems.

WARNING: Minimally invasive medical devices may vary from manufacturer to manufacturer. If minimally invasive medical devices and accessories produced by different manufacturers are used in one surgery, check the compatibility prior to initiation of the procedure.

WARNING: Verify That before each use, the outer surface of the portions of any ENERGIZED ENDOTHERAPY DEVICES which are intended to be inserted into a PATIENT is checked to ensure there are no unintended rough surfaces, sharp edges or protrusions which may cause HARM
WARNING: Use of accessories, transducers and cables other than those specified or provided by the manufacturer of this equipment could result in increased electromagnetic emissions or decreased electromagnetic immunity of this equipment and result in improper operation.

WARNING: PORTABLE RF communications equipment (including peripherals such as antenna cables and external antennas) should be used no closer than 30 cm (12 inches) to any part of the Ultrasound Surgical Equipment, including cables specified by the MANUFACTURER. Otherwise, degradation of the performance of this equipment could result.

WARNING: If the Transducer is obviously damaged, throw away any damaged components after cleaning and sterilization. Mark the damaged components clearly to avoid misuse.

WARNING: To avoid environmental pollution, disposable apparatuses and electronic wastes should be disposed according to the procedures and regulations of the hospital.

WARNING: When in danger, immediately disconnect your power supply.

WARNING: The active blade heats the tissue by friction and is intended to supply sufficient friction and shearing effect to cut and coagulate tissue in contact with the active blade. As a result, the user should use caution with the blade, clamp arm, and distal part of the shaft as they may exhibit an elevated temperature.

WARNING: Avoid use of Generator adjacent to or stacked with other equipment. If adjacent or stacked use is necessary, monitor the Generator and the other equipment to assure normal operation.

WARNING: The EMISSIONS characteristics of this equipment make it suitable for use in industrial areas and hospitals (CISPR 11 class A). If it is used in a residential environment (for which CISPR 11 class B is normally required) this equipment might not offer adequate protection to radio-frequency communication services. The user might need to take mitigation measures, such as relocating or re-orienting the equipment.

WARNING:A notice to the user and/or patient that any serious incident that has occurred in relation to the device should be reported to Reach Surgical, Inc. through Reachquality@reachsurgical.com. and the competent authority of the Member State in which the user and/or patient is established.

WARNING: This device seals vessels up to a maximum diameter of 7 mm depending on the instrument used. Refer to the instrument IFU for further information.

Note: For additional warnings and notices, please see the related instructions.

Chapter VIII - Electromagnetic Compatibility (EMC)

The product has passed the electromagnetic compatibility test, which meets the limitation requirements of IEC60601-1-2 standard for medical equipment. These restrictions provide reasonable protection against harmful interference in normal medical installations.

1. Equipment components refer to Table 1 Components of Ultrasound Surgical Equipment

2.The cable of the Ultrasound Surgical Equipment

No.	Cable Name	length (m)	Shield or not
1	The cable of Transducer	2.9	Yes
2	The cable of FSW2	3	Yes
3	The power cable	5	No
4	The Potential Equalization	0.03	No

3 . EMC performance

This equipment may be subject to radio frequency interference caused by other medical equipment and radio communications. To prevent such interference, this product has been tested according to IEC 60601-1-2 and meets its requirements. However, the Reach Surgical, Inc. does not guarantee that there will be absolutely no interference in individual installation environments.

If it is found that the device is interfered (which can be determined by turning the device on and off), the user (or maintenance personnel approved by Reach Surgical, Inc.) should try to take one or more of the following measures to solve the interference problem:

Adjust the direction or position of the device that affects it.

Increase the distance between this device and the sending device.

Use other power sources (rather than the power used to affect the equipment) to power this equipment.

Consult the supplier or service representative for other suggestions.

The manufacturer is not responsible for any interference caused by the following situations: use other interconnecting cables other than the recommended cables; alter or modify this equipment without permission. Unauthorized changes or modifications may cause the equipment lose efficacy.

All types of electronic equipment may cause electromagnetic interference to other equipment through the air or other cables connected to it. Do not use devices that can emit RF signals, such as cellular phones, radio transceivers, or radio control products, near this device, as this may cause the performance of this device to fail to meet the specified specifications. When such devices are close to this device, turn off the power of these devices. The medical personnel in charge of this equipment should instruct technicians, patients and other personnel who may be close to this equipment to fully comply with the above requirements.

To fully achieve the specified EMC performance, the user should install the product correctly according to the steps described in the manual. If there are any EMC-related problems, please contact the maintenance personnel approved by Reach Surgical, Inc.

The Transducer (with cable) and Shear are defined as the applied part of the whole system.

4. Precautions for product installation

The equipment can be used in a hospital environment but does not include radio frequency shielding rooms around active high frequency surgical equipment or where magnetic resonance impact equipment is placed, because the electromagnetic disturbance intensity in these locations is high.

Separation distance and impact of fixed radio communication equipment: magnetic field strength generated by fixed transmitters, such as base stations of wireless (cellular/cordless) telephones, land mobile radio receivers, amateur radio receivers, AM and FM radio broadcasts, and TV broadcasts Generators, etc., cannot be accurately measured theoretically. To assess the electromagnetic environment generated by fixed RF transmitters, measurement of the electromagnetic field should be considered. If the measured value of the magnetic field strength at the location of the device exceeds the corresponding radio frequency level specified in the "Anti-Interference Statement", the device should be inspected to ensure that it can operate normally. If abnormal operating conditions are found, additional measurements should be considered, such as reorienting or relocating the equipment, or using an anti-radio frequency room.

- 1) Use the Power Cord provided or designated by the Reach Surgical, Inc. Products equipped with a power plug should be plugged into a fixed power outlet with protective grounding. Do not use any type of adapter or converter to connect the power plug.
- 2) Keep this device away from other electronic devices as much as possible.
- 3) Follow the steps to connect the device.

General notes

- (1) The specification of the cable.

The use of cables provided by the Reach Surgical, Inc will not damage the EMC performance of this product. If unspecified

cables are used, the EMC performance of this equipment may be significantly reduced.

(2) Precautions for unauthorized modifications

The user shall not modify this product, otherwise the EMC performance of this product may decrease.

The modification of the product includes the following changes:

- a . Cable (length, material, and wiring, etc.).
- b . Equipment installation/layout.
- C . Equipment configuration/components.
- D . Equipment protection parts (cover opening/closing and cover fixing parts).

(3) All protective covers should be closed when operating the equipment.

This product is expected to be used in the electromagnetic environment specified below, and the purchaser and user of this product should ensure that it is used in this electromagnetic environment.

5. Basic performance

The Ultrasonic Surgical Equipment uses ultrasonic energy to incise soft tissues while simultaneously completing hemostasis and/or coagulation during the operation.

Guidance and MANUFACTURER'S declaration - ELECTROMAGNETIC EMISSIONS		
The Ultrasound Surgical Equipment is intended for use in the electromagnetic environment specified as follows. The customer or the user of the Ultrasound Surgical Equipment should assure that it is used in such an environment.		
Emissions test	Compliance	Electromagnetic environment - guidance
RF emissions CISPR 11	Group 1	The Ultrasound Surgical Equipment uses RF energy only for its internal function. Therefore, its RF emissions are very low and are not likely to cause any interference in nearby electronic equipment.
RF emissions CISPR 11	Class A	The EMISSIONS characteristics of this equipment make it suitable for use in industrial areas and hospitals
Harmonic emissions IEC 61000-3-2	Class A	
Voltage fluctuations/ flicker emissions I EC 61000-3-3	Complies	

Guidance and manufacturer's declaration - electromagnetic immunity
The Ultrasound Surgical Equipment is intended for use in the electromagnetic environment Specified as follows.

The customer or the user of the Ultrasound Surgical Equipment should assure that it is used in such an environment			
IMMUNITY test	IEC 60601 test level	Compliance level	Electromagnetic environment - guidance
Electrostatic discharge (ESD) IEC 61000-4-2	± 8 kV contact ± 2,4,8 ,15kV air	± 8 kV contact ± 2,4,8 ,15kV air	Floors should be wood, concrete, or ceramic tile. If floors are covered with synthetic material, The relative humidity should be at least 30 %.
Electrical transient/burst IEC 61000-4-4	± 2 kV for power supply lines ± 1 kV for input/output lines	± 2 kV for power supply lines ± 1 kV for input/output lines	Mains power quality should be that of a typical commercial or hospital environment.
Surge IEC 61000-4-5	± 1 kV line(s) to line(s) ± 2 kV line(s) to earth	± 1 kV line(s) to line (s) ± 2 kV line (s) to earth	Mains power quality should be that of a typical commercial or Hospital environment.
Voltage dips, short interruptions on power supply input lines IEC 61000-4-11	0 % UT; 0,5 cycle at 0°, 45°, 90°, 135°, 180°, 225°, 270° and 315° 0 % UT; 1 cycle and 70 % UT; 25/30 cycles Single phase: at 0° 0 % UT; 250/300 cycle	0 % UT; 0,5 cycle At 0°, 45°, 90°, 135°, 180°, 225°, 270° and 315° 0 % UT; 1 cycle and 70 % UT; 25/30 cycles Single phase: at 0° 0 % UT; 250/300 cycle	Mains power quality should be that of a typical commercial or Hospital environment. If the user of the Ultrasound surgical Equipment requires continued operation during power mains interruptions, it is recommended that the Ultrasound surgical Equipment be powered from an uninterruptible power supply or a battery.
Power frequency (50/60 Hz) Magnetic field IEC 61000-4-8	30 A/m	30 A/m	Power frequency magnetic fields should be at level characteristic. Of a typical location in a typical commercial or hospital environment.

Guidance and manufacturer's declaration - electromagnetic immunity
The Ultrasound Surgical Equipment aims at application under the electromagnetic environment specified as follows.
Customer or user of the Ultrasound Surgical Equipment should assure that it is used under such environment

IMMUNITY test	IEC 60601 test level	Compliance level	Electromagnetic environment-guidance
Conducted RF IEC 61000-4-6	3 Vrms 150 kHz to 80 MHz 6 V in ISM bands between 0.15 MHz and 80 MHz	3V	Portable and mobile RF communications Equipment should be used no closer to any part of the Ultrasound Surgical Equipment, including cables, than recommended separation distance calculated from the equation for frequency of the transmitter. Recommended separation distance $d = \left[\frac{3.5}{V_1}\right]\sqrt{P}$ $d = \left[\frac{3.5}{E_1}\right]\sqrt{P} \quad 80\text{MHz to } 800\text{MHz}$ $d = \left[\frac{7}{E_1}\right]\sqrt{P} \quad 800\text{MHz to } 2.7\text{GHz}$
Radiated RF IEC 61000-4-3	3 V/m 80 MHz to 2.7 GHz 80 % AM at 1 kHz	3V/m	where P is the maximum output power rating of the transmitter in watts (W) according to the transmitter manufacturer and d is the recommended separation distance in meters (m). Field strengths from fixed RF transmitters, as determined by an electromagnetic site survey, should be less than the compliance level in each frequency range. Interference may occur in the vicinity of equipment marked with the following symbol:  The ENCLOSURE PORT of ME EQUIPMENT and ME SYSTEMS shall be tested as specified in Table 9 of IEC 60601-1-2 using the test methods specified in IEC 61000-4-3.
Separation distances recommended between portable and mobile RF communications equipment and the Ultrasound Surgical Equipment			
Ultrasound Surgical Equipment aims at application under an electromagnetic environment in which radiated RF disturbances are controlled. Customer or user of the Ultrasound Surgical Equipment can help prevent electromagnetic interference by maintaining a minimum distance between portable and mobile RF communications equipment (transmitters) and the Ultrasound Surgical Equipment as recommendation as follows., according to the maximum output power of the communications equipment.			
Rated maximum	Separation distance according to frequency of transmitter /m		

output power of transmitter	150 kHz to 80 MHz	80 MHz to 800 MHz	800 MHz to 2.7 GHz
	$d = \left[\frac{3.5}{V_1}\right]\sqrt{P}$	$d = \left[\frac{3.5}{E_1}\right]\sqrt{P}$	$d = \left[\frac{7}{E_1}\right]\sqrt{P}$
0.01	0.117	0.117	0.233
0.1	0.36999	0.36999	0.73681
1	1.17	1.17	2.33
10	3.69986	3.69986	7.36811
100	11.7	11.7	23.3

Note: These guidelines may not apply in all situations. Electromagnetic propagation is affected by absorption and reflection from structures, objects, and people.

Chapter IX - Technical Conditions of the Equipment

WARNING: The Ultrasound Surgical Equipment must be operated within the specified ambient temperature range in accordance with the requirements.

WARNING: Make sure that the voltage of the output socket meets the requirements of the Generator. Incorrect connection of the power supply may damage the Generator and cause shock or fire hazard.

Components required for operation:

Generator (CSUS8000)

Transducer (TRA6)

Foot Switch (FSW2)

Shear: please refer to shear operation manual for more information.

Degree of Protection against Electric Shock: Type CF applied part

Degree of Protection against Electric Shock: Class I

Degree of Protection against Harmful Ingress of Water: Foot Switch: IPX8

Rate Input:

Supply voltage: 100-240V, 50/60Hz, 250VA

Operating conditions:

Working Temperature: 10°C-30°C

Relative humidity ≤ 70%.

Air pressure: 860hPa-1060hPa

Transportation and storage conditions:

Temperature: -40°C ~ +55°C (Generator, Transducer and Foot Switch)

Temperature: -10°C ~ +55°C (Shear)

Humidity: ≤80%

Air pressure: 860hPa-1060hPa

Operation Mode: Continuous work time: ≤15s; interval: ≥15s

Weight (unpacked): Generator: the nominal weight is 7kg

Fuse: 5*20 T5AH250V

Bulk Volume

CSUS 8000 type Generator: (H×W×D): 34cm×34cm×16cm

Disposal: For end life of equipment, they should be disposed according to local environmental requirement for waste treatment. There's cell battery which should be waste battery recycling.

AP/APG classification: Not AP/APG class equipment

The type of frequency control of the system: continuous automatic tuning of drive frequency, independent of load, during the operation.

Power reserve index: ≥2.5

Primary tip vibration excursion: 25μm ~ 110μm

Software Release Version: V01.01

Note: For replacement the fuse, contact the service personnel trained and authorized by Reach Surgical, Inc. or your local representative. And the replace procedure refer to the Service manual.

Chapter X - After-Sales Service and Warranty

Reach Surgical, Inc. warrants this product to be free from defects in material and workmanship under normal use and preventive maintenance for the respective warranty period shown below. Reach Surgical's obligation under this warranty is limited to die repair or replacement, at its option, of any product, or part thereof, which has been returned to Reach Surgical, Inc. or its Distributor within the applicable period shown below and which examination disclosed, to Reach Surgical 's satisfaction, to be defective. This warranty does not apply to any product, or part thereof, that has been.

(1) adversely affected due to use with devices manufactured or distributed by parties not authorized by Reach Surgical, Inc. (2) repaired or altered outside Reach Surgical 's factory in a way to in Reach Surgical 's judgment, affect its stability or reliability.

(3) subjected to improper use, negligence, or accident, or (4) used other than in accordance with the design and use parameters, instructions, and guidelines for the product or with functional, operational, or environmental standards for similar products generally accepted in the industry.

Reach Surgical 's products are warranted for the following periods after delivery to the original purchaser:

Transducer 1 year for the components and labor

Generator	1 year for the components and labor
Foot Switch	1 year for the components and labor

Unless superseded by applicable local law, this warranty is in lieu of all other warranties. Express or implied. Including the warranties of merchantability and fitness for a particular purpose. And of all other obligations or liabilities on the part of Reach Surgical, Inc. And is a purchaser's exclusive remedy. In no event shall Reach Surgical, Inc. be liable for special, incidental, or consequential damages including, without limitation. Damages resulting from loss of use, profits. Business or goodwill, other than as expressly provided by a specific law.

Reach Surgical, Inc. neither assumes nor authorizes any other person to assume for it any other liability in connection with the sale or use of any of Reach Surgical Inc. products. There are no warranties that extend beyond the terms hereof.

Reach Surgical, Inc. reserves the right to make changes to products built and/or sold by them at any time without incurring any obligation to make the same or similar changes on products previously built and/or sold by the Reach Surgical, Inc.