

TA60V

Anesthesia Machine

User Manual



Content

Explanation	- 1 -
Intellectual Property	- 1 -
Statement	- 1 -
Warranty and Repair Service	- 2 -
After-Sales Service	- 2 -
Foreword	- 3 -
Explanation	- 3 -
User	- 3 -
Images	- 3 -
Conventions	- 3 -
1.0 Safety	- 4 -
1.1 Safety Information	- 4 -
1.1.1 Warning	- 4 -
1.1.2 Caution	- 5 -
1.1.3 Caution	- 6 -
1.2 Device Symbol	- 7 -
2.0 Overview	- 9 -
2.1 System Overview	- 9 -
2.1.1 Intended Use	- 9 -
2.1.2 Contraindications	- 9 -
2.1.3 Product Description	- 9 -
2.2 Device View	- 10 -
2.2.1 Front side view of the anaesthesia machine	- 10 -
2.2.2 Breathing circuit view	- 12 -
2.2.3 Anaesthesia machine rear view (with stand)	- 13 -
2.2.4 Anaesthesia machine rear view (Wall)	- 14 -
3.0 Installation Guide	- 15 -
3.1 Stand Installation Guide	- 15 -
3.2 Anesthesia machine mounted on stand	- 15 -
3.3 Anesthesia vaporizer mounted to anesthesia machine	- 16 -
3.4 CO2 absorber Canister installation and removal	- 16 -
3.4.1 CO2 absorber Canister installation	- 17 -
3.4.2 CO2 absorber canister disassembly	- 17 -
3.5 Installation and disassembly of waste gas canister and waste gas recycling pipe	- 17 -
3.5.1 Installation of waste gas canister and waste gas recycling pipe	- 18 -
3.5.2 Dismantling of waste gas canister and waste gas recycling pipe	- 19 -
3.6 Wall-mounted anesthesia machine	- 19 -
4.0 Test before operation	- 21 -
4.1 Pre-Operation Testing Requirements	- 21 -
4.2 Pre-Operation Checklist	- 21 -
4.3 Check the system	- 22 -

4.4 Manual vent leak test	- 23 -
4.5 Air Supply Pipeline Test	- 23 -
4.6 Respiratory System Test	- 23 -
4.6.1 APL Valve Test	- 24 -
4.7 Preparation before Surgery	- 24 -
5.0 Operation	- 25 -
5.1 Oxygen Flow Setting	- 25 -
5.2 Set Up the Vaporizer	- 25 -
5.2.1 Add Anesthetic	- 25 -
5.2.2 Discharge anesthetic	- 27 -
5.3 Manual Ventilation Operation	- 28 -
6.0 Maintenance	- 29 -
6.1 Maintenance Timetable	- 29 -
6.2 Disinfection and cleaning methods	- 29 -
6.2.1 Wipe	- 30 -
6.2.2 UV exposure	- 30 -
7.0 Appendix	- 31 -
7.1 Attachment List	- 31 -
A.0 Product Specification	- 33 -
A.1 Safety Specification	- 33 -
A.2 Environment Specification	- 33 -
A.3 Physical Specifications	- 33 -
A.4 Air System Specifications	- 34 -
A.5 Respiratory System Specifications	- 34 -
A.6 Vaporizer	- 34 -
A.7 No Power AGSS	- 35 -

Explanation

Thank you for purchasing the Anesthesia Machine.

Before using the product, please carefully read the contents of this instruction manual in order to use the product correctly.

After reading, please keep this instruction manual properly so that you can refer to it at any time when you need it.

Product Name :	Anesthesia Machine
Model:	TA60V
Structure and Composition:	This product consists of an anesthesia machine, a vaporizer, a stand and a breathing circuit and accessories.
Scope of Application:	This anesthesia machine is used to provide inhalation anesthesia and respiratory support during animal anesthesia.
Manufacturer's name:	TOOTOO MEDITECH CO., LTD.
Address:	3A, Phase II, Smart Home, No. 76, Baohe Avenue, Baolong Community, Baolong Street, Longgang District, Shenzhen, Guangdong, China
Production Date:	See the nameplate on the back cover of the product
The Edit Date of of the Manual:	2022-01

Intellectual Property

The intellectual property rights of this instruction manual and its corresponding products belong to this company. Without the written consent of this company, no individual or organization can copy, modify or translate any part of this instruction manual.

Statement

This company has the final right to interpret this instruction manual.

This company is responsible for the safety, reliability and performance of products only if all of the following requirements are met, namely:

Assembly operations, expansions, readjustments, improvements, and repairs are performed by this company approved professionals;

All repairs involve the replacement of parts and accessories and consumables used in conjunction with them are the original (original) of this company or approved by this company;

The relevant electrical equipment complies with the national standards and the requirements of this instruction manual;

Product operation is carried out in accordance with this instruction manual.

Warranty and Repair Service

The warranty period of the purchased product is subject to the sales contract.

Consumables: Refers to disposable consumables that need to be replaced after each use or fragile materials that are replaced regularly. Consumables have no warranty.

The warranty period starts from the "Installation date" filled in the "Equipment Warranty Card" attached to the product. The "Equipment Warranty Card" is the only proof for calculating the warranty period. In order to protect your rights, please fill in the warranty card after the installation of the equipment, and hand over the second copy of the warranty ("this company's retention") to the installer or mail it back to this company User Service Department.

Please note that the following situations will not be covered under warranty:

1. The customer fails to fill in and return the warranty card within 30 days after the completion of the installation and acceptance;
2. The serial number of the equipment provided by the customer is incorrect (our company confirms the warranty with the serial number of the equipment).

During the warranty period, the products can enjoy free after-sales service; but please note that even during the warranty period, if the product needs to be repaired due to the following reasons, this company will implement a charged maintenance service, and you need to pay the maintenance fee and accessories fee :

Man-made damage;

Improper use;

Irresistible natural disasters;

Replace or use parts, accessories not approved by this company or repaired by persons not authorized by this company;

Other failures not caused by the product itself.

The failure of the instrument caused by the use of consumables not approved by this company is not within the scope of maintenance services provided by this company.

After the warranty period expires, this company can continue to provide paid maintenance services.

If you do not pay or delay in paying the fee for the maintenance service, this company will temporarily suspend the maintenance service until you pay.

We strongly recommend that you use this product in a manner consistent with this manual and under the conditions and environment specified in this manual.

After-Sales Service

Company name: TOOTOO MEDITECH CO., LTD.

Address: 3A, Phase II, Smart Home, No. 76, Baohe Avenue, Baolong Community, Baolong Street, Longgang District, Shenzhen, Guangdong, China

Postcode: 518029

Company website: www.newtootoo.com

Tel:+86-755-28306385

Foreword

Explanation

This manual describes the use, function and operation of the product in detail. Before using this product, please read and understand the contents of this manual carefully to ensure the correct use of this product and the safety of animals and operators.

This manual introduces this product according to the most complete configuration, so some contents may not be applicable to the purchased product. If you have any questions, please contact this company.

Please place this manual near the product so that it can be easily and promptly obtained when needed.

User

This instruction manual is only for use by professionally trained anesthesiologists

Images

All illustrations provided in this manual are for reference only, and the settings or data in the illustrations may not be exactly the same as the actual display seen on the product.

Conventions

: Indicates quoted chapters.

→: This symbol is used to indicate the steps in the operation

1.0 Safety

1.1 Safety Information

WARNING— Indicates a potentially hazardous or unsafe operation which, if not avoided, could result in death or serious personal injury or property damage.

CAUTION— Indicates a potentially hazardous or unsafe operation, which, if not avoided, could result in minor personal injury, product failure, damage, or property damage.

NOTE - Emphasizes important notices, provides instructions or explanations for better use of this product.

1.1.1 Warning

Warning: do not operate the anesthesia machine before reading this manual.

Warning: Before operation, ensure that the machine, connecting line and accessories can work normally and safely.

Warning: Do not use this machine in an environment where flammable or explosive materials are placed to prevent fire or explosion.

Warning: Repairs or upgrades to the machine may only be performed by service personnel trained and authorized by the company. The fresh air must not be turned off until the anesthesia vaporizer is turned off. The anesthesia vaporizer cannot be turned on without fresh air. Otherwise, a high concentration of anesthetic vapor can enter the machine pipeline and the surrounding air and cause harm to people and things.

Warning: Before moving the anesthesia machine, remove items from the top plate and stand to avoid a tipping hazard of the anesthesia machine.

Warning: Do not use the anesthesia machine when there is a leak in the respiratory system

Warning: Check the passive AGSS processing system specifications as well as the specifications of the anesthesia machine to ensure compatibility and prevent mismatched processing systems.

Warning: Using the incorrect connector can be dangerous. Make sure all components are using the correct connectors.

Warning: Disposable items such as single-use breathing hoses, soda lime may be considered potentially biohazardous and should not be reused. When handling these items, follow hospital and local regulations on contaminants and biohazards.

Warning: Do not use the top plate to push and lift the machine. Please use the handle

Warning: If the anesthesia machine is not disinfected in time after use, there is a risk of cross infection. Do not perform maintenance on the machine while the animal is using it

1.1.2 Caution

Caution: For animal safety, please use the accessories specified in this manual.

Caution: When the machine and its accessories are about to exceed their lifespan, they must be disposed of in accordance with relevant local regulations or hospital regulations.

Caution: Please install or transfer the machine properly to prevent the machine from falling, bumping, being damaged by strong vibration or other mechanical external forces

Caution: When the trolley is configured, the anesthesia machine can be tilted 10° to maintain stability. Please do not hang objects on both sides of the anesthesia machine in order to avoid the danger of dumping.

Caution : Please effectively fix the machine placed on the top cover to avoid accidental sliding.

Caution : The use and storage of the air source hose assembly in an environment such as ultraviolet rays, oxidants, high temperature and humidity should be prevented or avoided, so as to prevent the aging of the hose and the pressure release from hose assembly to could cause harm to people, animals and objects.

Caution: This machine is not intended for use in a magnetic resonance (MRI) environment

Caution : Unlocked casters may move unexpectedly when a stand is configured. Casters should be locked while using this machine.















1.1.3 Caution

Caution: Install the machine in a location that is easy to observe, operate and maintain. Please observe the relevant information of the machine at a position in front of the anesthesia machine within 4m from the front panel of the anesthesia machine.

Caution: Please place this manual near the machine so that it can be easily and promptly obtained when needed.

Caution : This manual introduces this product according to the most complete configuration, and the purchased product may not have some configurations or functions.

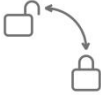
1.2 Device Symbol

Symbol	Description	Symbol	Description
	Caution! Read product manual		Defibrillation Proof Type BF Applied Parts
	Oxygen Port		Flowmeter
	Flowmeter knob, turn counterclockwise to increase flow		O2 Flush
	ACGO Switch		APL Pressure adjustment knob, turn clockwise to increase the set pressure
	Inspiratory Valve Port		Expiratory Valve Port
	Breathing Bag Port		ACGO Port
MIN	Minimum	MAX	Maximum
10 kg MAX 22 lbs MAX	Maximum load		Soda lime filling maximum
	CO2 Absorber Canister locking and unlocking		AGSS Exhaust Port
IPX1	Protection level against water, dust, etc.		Serial Number

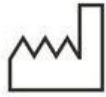

Manufacturing date



avoid rain

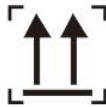

face up

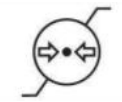

Atmospheric pressure limit



Humidity Limit



temperature limit



Fragile handle

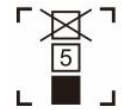

Stacking layer limit



Not for use in a magnetic resonance (MRI) environment



This product contains some harmful substances, which can be used with confidence within the environmental protection use period. After the environmental protection use period is exceeded, it should enter the recycling system. The environmental protection use period of this product is 20 years.

2.0 Overview

2.1 System Overview

Please refer to the "3.0 Installation Guide" of this manual for the installation of the anesthesia machine.

2.1.1 Intended Use

This anesthesia machine is used to provide inhalation anesthesia and respiratory support during animal anesthesia.

Warning: The user of this anesthesia machine should be a full-time anesthesiologist and have received training in the use of the anesthesia machine.

2.1.2 Contraindications

Unknown

2.1.3 Product Description

This product consists of an anesthesia machine , a vaporizer, a stand, a breathing circuit and accessories

This anesthesia machine provides the following ventilation modes:

- Manual ventilation mode
- Acyclic ventilation mode

2.2 Device View

2.2.1 Front side view of the anaesthesia machine

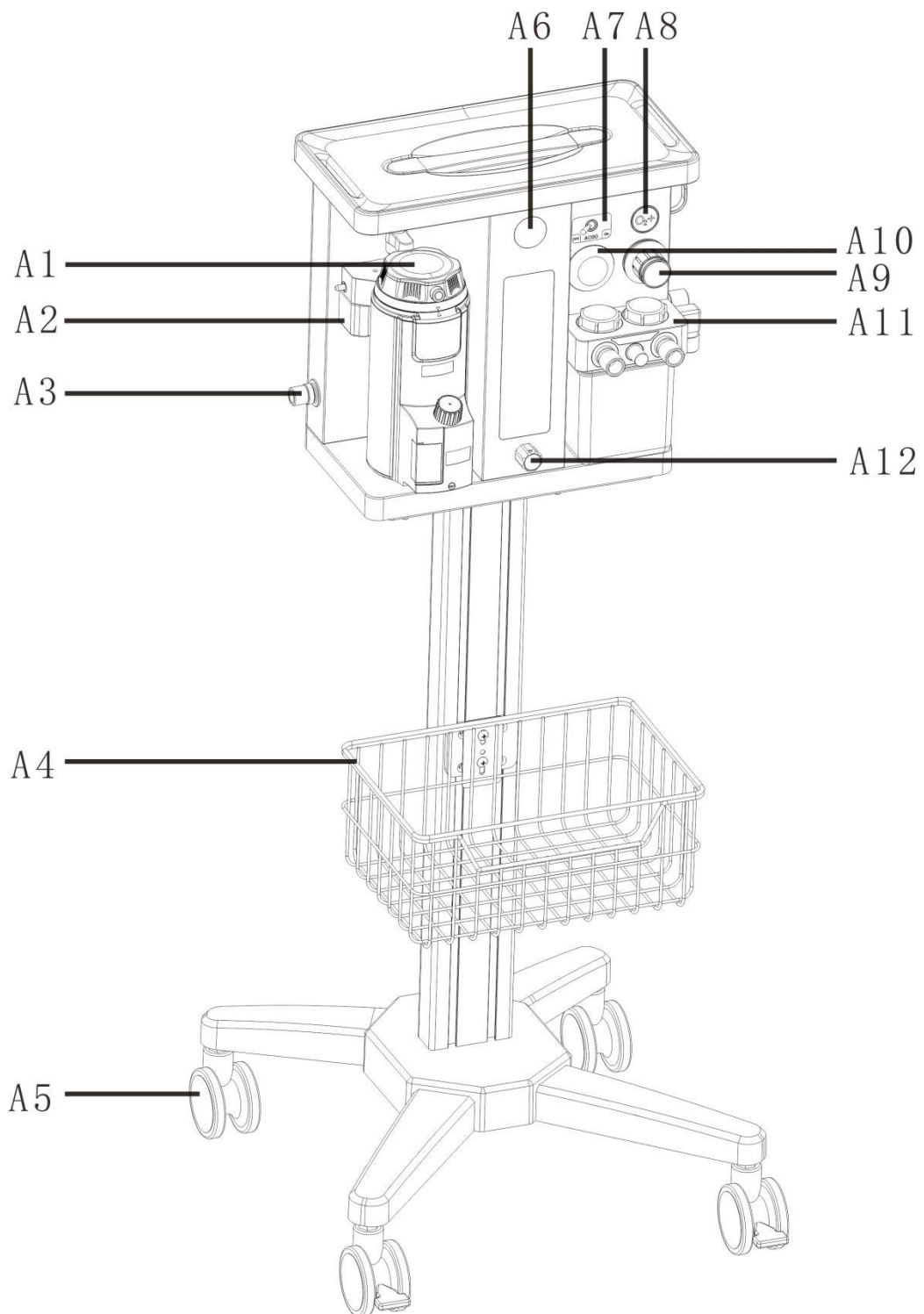

2-1 Front side view of main unit

Serial	Part	Description
A1	Vaporizer	A device that can effectively output the concentration of anesthetics. Each vaporizer is suitable for a specific anesthetic.
A2	Vaporizer base	It is used to install the vaporizer. After the vaporizer is removed, it can also ensure the normal ventilation of the air circuit.
A3	Oxygen Port	Oxygen connection port
A4	Storage basket	Used to store various medical items.
A5	Casters	Machine can be moved through casters, all four casters with brakes
A6	Air pressure gauge	Used to display the input air pressure
A7	ACGOS Switch	Used to turn on/off the ACGO function. For fresh gas output via ACGO interface.
A8	O2 Flush	Provides a fixed flow of oxygen to the inspiratory branch of the respiratory system
Caution: In the case of testing pressing the rapid Oxygenation button, please ensure that the connection to the animal has been disconnected		
A9	APL vale	Rotary pressure regulator for setting the limiting pressure of the breathing system during manual ventilation. The scale above it represents the approximate pressure. Turning the APL valve clockwise increases the pressure limit and counterclockwise decreases the pressure limit. After pressing the APL valve, the limiting pressure will increase by about 30cmH2O on the original basis, and it will return to the original setting pressure after releasing it.。
A10	Airway Pressure Gauge	Indicates airway pressure
A11	loop	Integrated recirculating breathing circuit
A12	flowmeter	Displays the flow of oxygen

Table 2-1 Main unit front side view parts list

2.2.2 Breathing circuit view

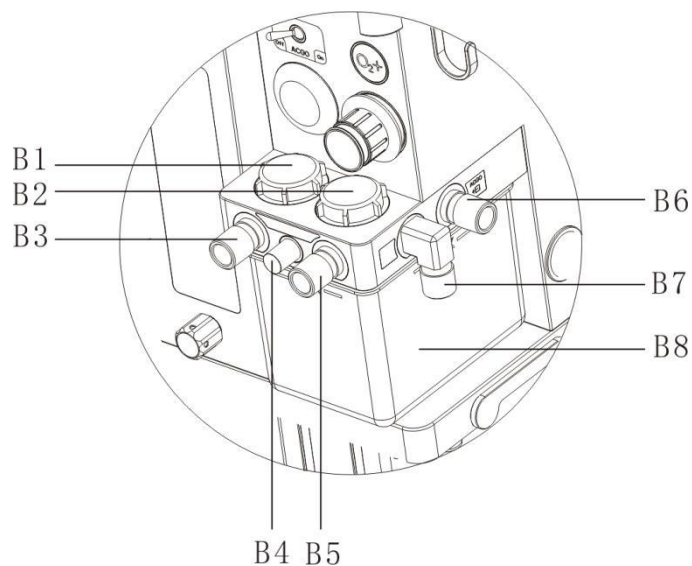
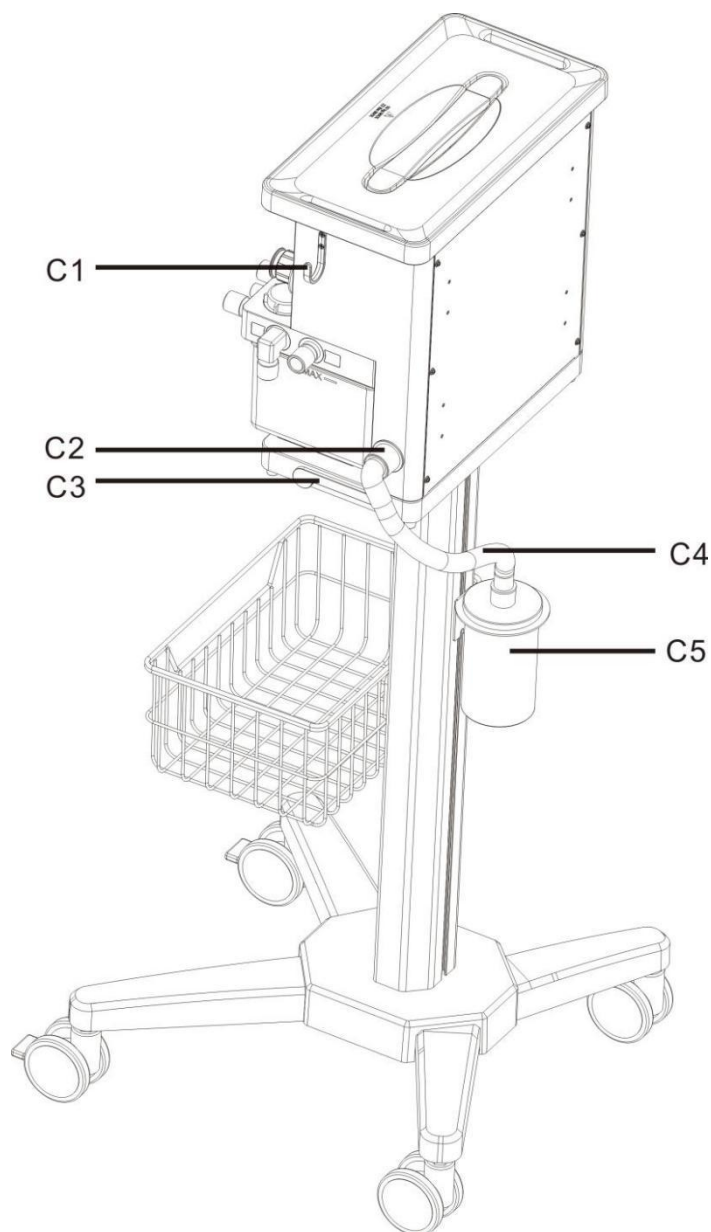

Image 2-2 Breathing circuit view

Serial	Part	Description
B1	Inspiratory check valve observation window	The status of the inspiratory check valve can be observed from outside the device.
B2	Expiratory check valve viewing window	The status of the expiratory check valve can be observed from outside the device
B3	Inspiratory port	Inspiratory branch connector
B4	Test plug	When testing for leaks, it is used to connect the outlet end of the breathing circuit
B5	Expiratory port	Expiratory branch connector
B6	ACGO Port	For connecting to an open breathing circuit
B7	Breathing bag Port	For connecting the storage bag
B8	CO2 absorber canister	Containers for filling soda lime, absorbing CO2

Table 2-2 Breathing Circuit View Parts List

2.2.3 Anaesthesia machine rear view (with stand)



Picture 2-3 Anaesthesia machine rear view

Serial	Parts	Description
C1	Hook	For hanging breathing circuit or other accessories
C2	AGSS Port	for exhaust
C3	CO2 absorber canister lock and unlock handle	Used to control the installation of CO2 absorber canister.
C4	Exhaust gas recovery line	Connection line for connecting the AGSS port to the exhaust gas tank
C5	Waste gas tank	Used to absorb anesthetic gas from AGSS exhaust gas

Table 2-3 Anaesthesia machine rear side view parts list

2.2.4 Anaesthesia machine rear view (Wall)

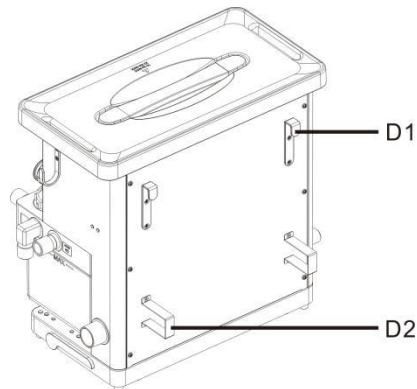

Picture 2-4 Anaesthesia machine rear view (Wall)

Serial	Part	Description
D1	Wall hook	When the main unit is wall mounted on the wall, hang on the wall bracket
D2	Wall support pad	When the host is wall mounted on the wall, support the host so that the host is perpendicular to the wall

Table 2-3 Anaesthesia machine rear view (wall mounted) parts list

3.0 Installation Guide

Warning: Disposable items such as single-use breathing hoses, soda lime may be considered potentially biohazardous and should not be reused. Dispose of these items in compliance with hospital and local regulations for contaminants and biohazards

Caution: This manual introduces this product according to the most complete configuration. The purchased product may not have some configurations or functions.

Note: The part numbers in all the figures in this chapter, if they appear in the previous chapters, have the same numbers and the same names as the previous chapters.

3.1 Stand Installation Guide

If you choose a stand, please install the stand by referring to the "accompanying documents" in the stand box.

3.2 Anesthesia machine mounted on stand

Serial	Item
F1	Anesthesia Machine
F2	Stand support plane
F3	Locking screw

- (1) Place the anesthesia machine on the support plane of the stand, aligning the mounting screw holes
- (2) Screw the locking screw upwards from the lower part of the support surface of the stand into the anesthesia machine, and tighten the locking screw.
- (3) Refer to the picture after installation2-1.

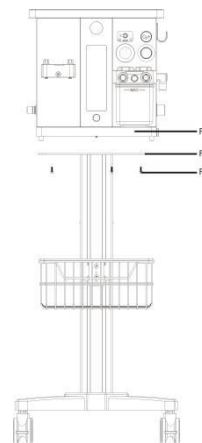

Image 3-2 Anesthesia machine installed on the stand

3.3 Anesthesia vaporizer mounted to anesthesia machine

Serial	Item
A1	Vaporizer base
G1	Connector
G2	Locking knob
A2	Vaporizer

- (1) Align the mounting hole of the evaporator with the connector on the base of the evaporator, and then install the evaporator on the bottom of the evaporator.
- (2) Rotate the locking knob on the top of the evaporator clockwise, and the rotation angle is 90 degrees. Lock the evaporator.
- (3) Refer to the picture after installation 2-1.

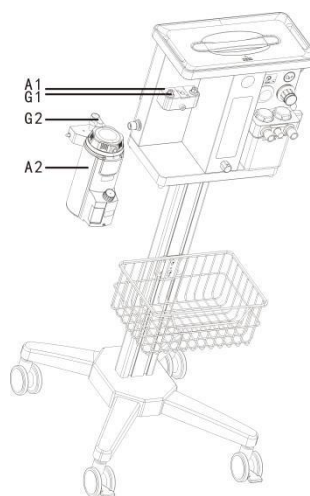

Image 3-3 Vaporizer mounted to anesthesia machine diagram

3.4 CO2 absorber Canister installation and removal

The views of the CO2 absorber canister before and after installation are as follows:

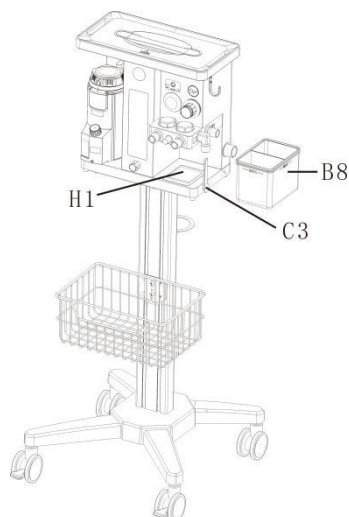

Image 3-4-1 Schematic diagram before installation

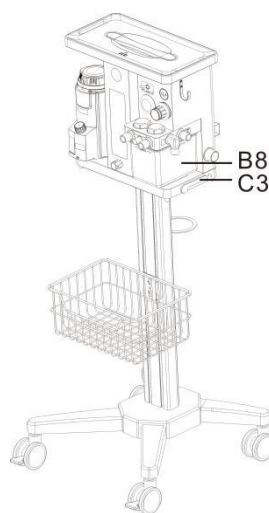

Image 3-4-2 Schematic diagram after installation

Serial	Part	Description
B8	CO2 Absorber Canister	Vessel for filling soda lime, absorbing CO2
C3	CO2 Absorber Canister Lock and Unlock Handle	Used to control the installation of CO2 absorber canister.
H1	CO2 Absorber Canister Support	When rotating the canister disassembly knob, the support will rise or fall

3.4.1 CO2 absorber Canister installation

- (1) Make sure that the CO2 absorber canister is filled with qualified soda lime, and the filling amount does not exceed the MAX marking line.
- (2) Make sure the lock and unlock handle of the CO2 absorber canister is in the vertical position as shown in Figure 3-4-1.
- (3) Place the CO2 absorber canister on the canister support, making sure to place it on the center of the positioning.
- (4) Rotate the lock and unlock handle of the CO2 absorber canister clockwise to the horizontal position shown in Figure 3-4-2.
- (5) CO2 absorber canister is installed, as shown in the figure after installation 3-4-2.

3.4.2 CO2 absorber canister disassembly

The dismantling of the CO2 absorber canister also refers to the replacement of soda lime. The operation steps are as follow:

- (1) Before disassembly of the CO2 absorber canister as shown in the figure 3-4-2
- (2) Lock and unlock the canister and turn it counterclockwise to the vertical position, image 3-4-1
- (3) Remove the CO2 absorber canister
- (4) Pour out the used soda lime from the CO2 absorber canister (dispose of soda lime in accordance with hospital and local regulations on contaminants and biohazards)
- (5) After the disassembly of the CO2 absorber canister is completed, if you want to continue to use the equipment, or before using the equipment next time, please operate according to 3.4.1 and install the CO2 absorber canister.

3.5 Installation and disassembly of waste gas canister and waste gas recycling pipe

The schematic diagram of the waste gas canister and the waste gas recycling pipe before installation is as follows, please refer to the diagram after installation 2-3.

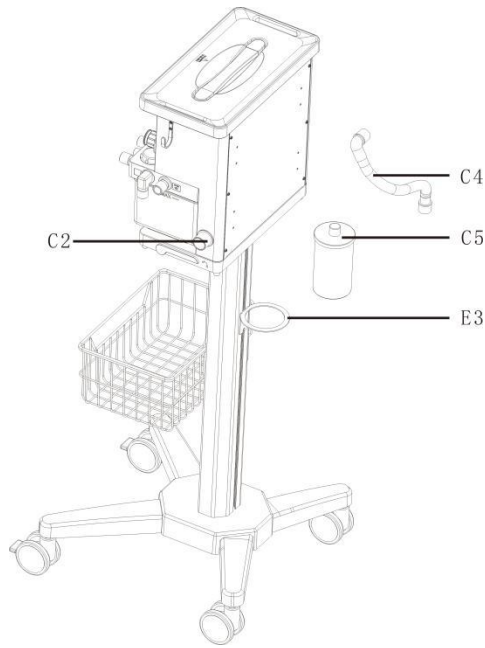

Image 3-5 Schematic diagram of the waste gas canister and the waste gas recycling pipe before installation

Serial	Part	Description
C2	AGSS Port	for discharging waste gas
C4	Waste gas recycling pipe	Connection line for connecting the AGSS port to the waste gas canister
C5	Waste gas canister	Used to absorb anesthetic gas from AGSS waste gas
E3	Waste gas canister Support	For the placement of waste gas canister

3.5.1 Installation of waste gas canister and waste gas recycling pipe

- (1) Place the waste gas canister in the center round hole of the bracket
- (2) Insert the right-angle fitting end of the waste gas recycling pipe into the inner hole of the AGSS fitting, and press it tightly
- (3) Insert the direct head end of the waste gas recycling pipe into the outer edge of the top joint of the waste gas canister, and press it tightly. So far, the waste gas canister and waste gas recycling pipe have been installed on the equipment.

3.5.2 Dismantling of waste gas canister and waste gas recycling pipe

The disassembly of the waste gas canister and the waste gas recycling pipe also refers to the replacement of the waste gas canister. The operation steps are as follows:

- (1) Pull out the joint at both ends of the waste gas recycling pipe.
- (2) Remove the waste gas canister.
- (3) After the disassembly is completed, if you need to continue to use the equipment or before using the equipment next time, please replace the waste gas canister with a new one. Repeat 3.5.1 operation.

3.6 Wall-mounted anesthesia machine

Wall bracket installation as shown below:

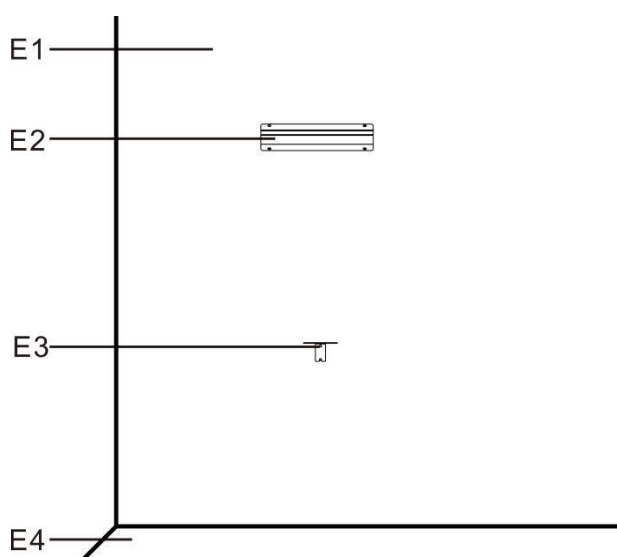

Image 3-6 Wall bracket view

Serial	Part	Description
E1	Wall	For installing the wall bracket
E2	wall bracket	When the machine is wall-mounted, hang the machine
E3	Waste gas canister bracket	For the placement of waste gas canister
E4	Ground	Ground

Table 3-6 Wall Bracket View Parts List

Explanation:

In order to facilitate the removal of the waste gas canister. The two fixing screw holes of the waste gas canister bracket, the recommended vertical distance between the upper screw holes and the host wall bracket is 600mm.

Wall-mounted anesthesia machine:

1. Hang the upper wall hooks on the back of the anesthesia machine shown in Figure 2-4 (with the wall accessories installed on the anesthesia machine) in the installation slot of the main machine wall bracket shown in Figure 3-6.
2. Install the waste gas canister on the bracket as shown in Figure 3-6
3. Connecting the waste gas recycling pipe

4.0 Test before operation

4.1 Pre-Operation Testing Requirements

The anesthesia machine is pre-operated according to the test intervals listed below. Please refer to the specific steps or precautions in this manual.

Pre-operational testing should be performed in the following cases:

- ◇ Before using the device on each animal
 - Leak test
 - Air Supply Pipeline Test
 - Vaporizer test
 - Respiratory system test
 - AGSS Check
 - Check the anesthetic absorber
 - Preoperative examination
- ◇ After servicing or maintenance of the anesthesia machine
 - Preoperative examination
 - Air Supply Pipeline Test
 - Respiratory system test
 - AGSS Check
 - Preoperative examination

Caution: Do not use the machine if the pre-operation test has not passed. Please contact our company's technical support

4.2 Pre-Operation Checklist

Warning: To ensure the normal operation of the machine, and the safety of users and animals, please follow all inspection procedures established by the hospital before anesthetizing animals.

- Before operating the anesthesia machine for the first time each day, the following should be performed:

1. Check that the vaporizer contains enough anesthetic. Check whether the dosing port of the vaporizer is tightly closed.

2. For narcotic absorbers, check that they have gained more than the claimed weight gain.

- Before each administration of anesthesia, the following should be performed:

1. Inspect the machine for damage or dangerous conditions. Make sure all necessary equipment and items are in place, such as medication, carbon dioxide absorbent (not depleted) conditions.

2. If using central gas supply or gas cylinder supply, check that the O₂ pressure is within the specified range (ie 280-600kpa/40-87psi)

3. Check ventilation in manual mode.

- After replacing the CO₂ absorbers or breathing circuit, do the following:

1. Leak test

4.3 Check the system

During the inspection of the system, ensure that the following requirements are met:

1. The device is connected correctly and in good condition.

2. System Check:

- a. Whether damage to flow meter, vaporizer, pressure gauge and air supply line
- b. Whether the respiratory system is complete and equipped with sufficient carbon dioxide absorbers

3. Check others:

- a. Is the flow control valve closed
- b. Is the vaporizer closed
- c. Is the vaporizer filled with enough medicine

4. All parts connected correctly

5. The breathing system is connected correctly and the breathing circuit is intact

6. The air supply system is connected and the pressure is normal

7. Required emergency equipment is in place and in good condition

-
8. Check the color of the soda lime in the canister. If the color change is noticeable, replace the soda lime immediately
 9. Appropriate narcotic drugs and emergency drugs are available
 10. The casters are not damaged or loose, and they are locked so that the anesthesia machine cannot be moved
 11. Make sure the breathing system is in place
 12. Check whether O₂ flush is working properly.

4.4 Manual vent leak test

1. Connect the air bag to the air bag connector.
2. Make sure the Y shape pipe is closed and the flowmeter is off.
3. Set the APL valve at 30cmH₂O.
4. Press O₂ flush so that the airway pressure gauge reads at 15~25cmH₂O
5. Release O₂ flush, observe the airway pressure gauge to ensure that the pressure gauge reading does not drop more than 10cmH₂O from 20cmH₂O within 15s.

4.5 Air Supply Pipeline Test

1. Connect the oxygen to the air supply port of the anesthesia machine and turn on the switch.
2. Adjust the flow control knob to adjust the flow control to the middle level of the measuring range
3. Make sure the pressure indication of the air source pressure gauge is in the range of 280-600kpa.
4. Cut off oxygen supply.
5. Make sure that the air pressure gauge indicates the value back to the "0" position

4.6 Respiratory System Test

Warning: If there is a foreign object in the breathing system, it will block the gas flow to the animal, which may cause death or injury. Please make sure that there are no test plugs or other foreign objects in the breathing system.

Warning: Do not use the test plug with too small rest, which is easy to fall into the respiratory system, please use the test plug of the machine.

-
1. Make sure the breathing system is intact and connected correctly
 2. Make sure the check valve on the breathing system is working properly
 - a. If the inspiratory check valve opens during inspiration and closes at the beginning of exhalation, the inspiratory check valve is working properly.
 - b. If the expiratory check valve opens during exhalation and closes at the beginning of inspiration, the expiratory check valve is working properly.

4.6.1 APL Valve Test

1. Connect the breathing bag to the breathing bag connector
2. Connect the Y-piece on the breathing circuit in the breathing circuit to the test plug.
3. Adjust the APL valve control knob so that the pressure of the APL valve is at 30cmH₂O.
4. Set the flow rate of the oxygen flowmeter to 3L/min, for example, the storage bag is full.
5. Make sure the reading on the airway pressure gauge is: within the range of 20~40cmH₂O.
6. Keep pressing the APL valve after the airway pressure gauge stabilizes. Observe the reading of the airway pressure gauge at the same time, it can reach 40~80cmH₂O.
7. Adjust the APL valve control knob so that the opening pressure of the APL valve is at the minimum state (MIN position)
8. Make sure the reading on the airway pressure gauge does not exceed 10cmH₂O.
9. Turn the flow control knob of the oxygen flowmeter to set the O₂ flow to minimum (turn off the flowmeter) and verify that the reading on the airway pressure gauge does not drop below 0

4.7 Preparation before Surgery

1. Ensure that airway pressure maintenance equipment/manual ventilation and endotracheal intubation equipment, as well as appropriate anesthesia and emergency medicines, are available.
2. Connect the Breathing bag to the breathing bag port.
3. Turn off the vaporizer.
4. Turn the APL valve to the MIN position to fully open the APL valve.
5. Make sure the breathing system is properly connected and intact.

5.0 Operation

5.1 Oxygen Flow Setting

1. Connect the oxygen source and make sure the air source has sufficient pressure.
2. The flow of oxygen in the input fresh gas can be controlled by the knob of the oxygen flowmeter, and the flowmeter displays the flow value of oxygen in the fresh gas.

5.2 Set Up the Vaporizer

Press and turn the concentration control knob on the vaporizer to set the concentration of the anesthetic to the appropriate position.

Caution: Atmospheric pressure may differ from the calibrated pressure of the anesthesia vaporizer, which may result in inaccurate anesthetic output. During the use of anesthetics, the operator should continuously monitor the concentration of the anesthetic to determine whether the output concentration is accurate

Caution: Sharp pulls or tilts greater than 30° can result in incorrect concentrations when the vaporizer is on

Caution: If the vaporizer will not be used within 6 months, drain the anesthetic from the vaporizer

Caution: Before operation, check the anesthetic liquid level in the vaporizer. If the anesthetic liquid level is below the min line, you need to add anesthetic agent.

5.2.1 Add Anesthetic

Check the following items before adding anesthetics:

1. Check the vaporizer if it is in a good condition
2. The dial remains at the "0" position
3. Note the expiry date of the anesthetic
4. Wait 15 minutes for the initial addition of anesthetic to the vaporizer to saturate concentration of the anesthetic

Warning: Only add the specified anesthetics to the vaporizer. Please check the name and color of the anesthetic on the vaporizer and anesthetic bottle before use. Isoflurane is purple, sevoflurane is yellow, and enflurane is orange.

Warning: If the wrong anesthetic or other substance is added to the vaporizer, immediately stop using it to prevent health hazards. If the above occurs, mark this anesthesia vaporizer and contact the dealer for repair.

Pour-Fill Dosing Method

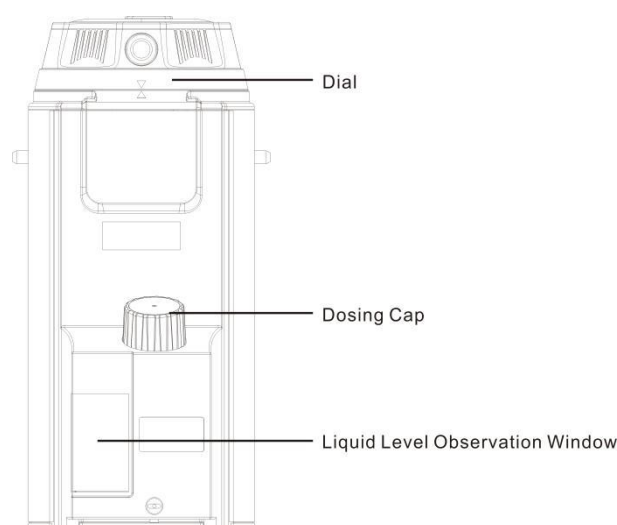

1. Set the dial to "0"
2. Slowly unscrew the doser cap counterclockwise to slowly release the pressure in the vaporizer
3. Unscrew the cap of the anesthetic agent bottle and slowly pour the anesthetic agent into the doser receiver
4. When adding medicine, check the injection liquid level from the window. The height of the liquid medicine is not allowed to exceed the maximum liquid level scale, otherwise it may cause the output concentration error and so on. If the maximum level mark has been exceeded, the anesthetic agent will overflow through the overflow hole and the excess liquid will need to be drained (see "Draining Anesthetic Agent" on page 22) until the liquid level of the liquid medicine drops below the maximum mark
5. Tighten the doser cap clockwise. If this is not done correctly, the next time the vaporizer is turned on, fresh gas and anesthetic may be spilled

Warning: If the vaporizer is not turned back to the "0" position, there may be a large amount of anesthetic vaporized and spilled

Caution: After rotating the dial to the "0" position, please wait at least 5s before turning on the anesthesia vaporizer to balance the pressure and prevent the overflow of fresh gas and anesthetic vapors.

5.2.2 Discharge anesthetic

Warning: Discharged anaesthetic must be handled, stored or disposed of as a drug, or misuse of anaesthetic may result

Warning: Please tighten the dosing cap and dosing knob after the vaporizer is discharged, otherwise, the anesthetic may overflow when the vaporizer is turned on next time

Warning: The anesthetic discharged from the vaporizer is not reusable

Warning: When the vaporizer discharges, do not overfill the anesthetic bottle, otherwise it will cause the anesthetic to overflow

Pour-fill Discharge Method

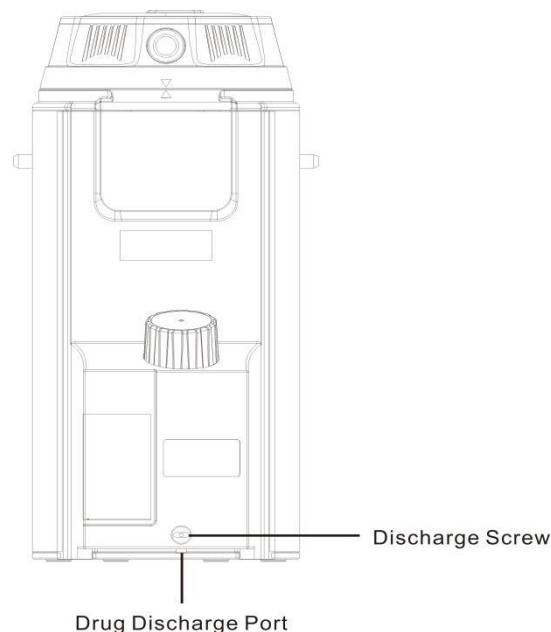

1. Set the dial to "0"
2. Take the correct anesthetic bottle and place it under the discharge port at the

bottom of the dosing system

3. Slowly turn counterclockwise to open the doser cap
4. Drain the anaesthetic until no anaesthetic is visible in the sight glass and no anaesthetic continues to flow into the bottle. If necessary, close the dispensing knob in time and continue to discharge with another anesthetic bottle
5. After the anesthetic is emptied, close the dispensing knob clockwise, close the cap of the anesthetic bottle, and tighten the dosing cap.

5.3 Manual Ventilation Operation

1. Rotate the APL valve control knob to adjust the pressure in the breathing system within the appropriate range
2. If necessary, press O2 flush "O2+" to inflate the storage bag
3. In manual ventilation, the APL valve is used to regulate the peak pressure in the breathing system and the amount of gas in the breathing bag. When the pressure of the breathing system rises to the pressure limit set by the APL valve, the APL valve is opened, releasing the excess gas in the breathing system.

6.0 Maintenance

6.1 Maintenance Timetable

This schedule is based on the minimum maintenance times specified for the typical use of 2000 hours per year. If the actual use time per year is longer than the typical situation, the maintenance work of the equipment should be more frequent

Caution: When cleaning and installing, inspect parts and seals for damage, replace and repair if necessary.

Minimum Frequency	Maintenance
Daily	Check the weight of waste gas canister; check the rapid oxygen supply function to ensure normal use; use a soft cloth, mild soap or water to clean the surface of the anesthesia machine and the CO2 absorber canister
Weekly	Check the inspiratory/expiratory valve seals for damage; check the flaps in the inspiratory/expiratory valve for damage
Every two week	Drain the vaporizer
Do if it is necessary	If the color of the absorbent changes, replace the absorbent in CO2 absorber canister. If the transfer system hose is damaged, replace it. If the air supply hose assembly is damaged, replace it. If the APL valve relief pressure deviation is too large, replace the APL valve

Table 6-1 Maintenance Schedule

6.2 Disinfection and cleaning methods

Warning: When cleaning and sterilizing, please ensure the applicability of the cleaning and sterilization method to each component, and ensure the correctness of the cleaning and sterilization method

Warning: All liquids should be kept away from electronic components. Do not allow liquids to penetrate into the device

Caution: Please clean and disinfect this equipment as needed before using it for the first time. Please refer to this chapter for cleaning and disinfection methods

Caution: Do not use abrasive cleaners such as steel wool, silver polish or cleaners. The pH value of the cleaning solution must be between 7.0 and 10.5

Name	Category
Water	Detergent
Soapy water (PH value is 7.0~10.5)	Detergent
Alcohol (75%)	Moderate disinfectant
UV	/

Table 6-2 Cleaners and Disinfectants

6.2.1 Wipe

- When cleaning the surface of the anesthesia machine, please use a weak alkaline detergent (water, soapy water with a pH value of 7.0~10.5) soaked in a damp cloth to wipe the surface of the anesthesia machine shell. When disinfecting the surface of the anesthesia machine, use a damp cloth soaked in a solution of moderate disinfectant (75% alcohol) to wipe the surface of the anesthesia machine.
- After cleaning or disinfecting the enclosure, use a dry, lint-free cloth to remove residual cleaner or disinfectant solution.

6.2.2 UV exposure

When sterilizing the surface of the anesthesia machine by ultraviolet irradiation, place the anesthesia machine at a distance of 1m under a 30W ultraviolet lamp for irradiation, and the irradiation time is not less than 60 minutes.

Caution: UV radiation is harmful to the human body, please do not stay in the UV room during the radiation

7.0 Appendix

- Caution:** Use only the accessories specified in this chapter, using other accessories may cause equipment failure
- Caution:** Disposable accessories can only be used once, repeated use may result in performance degradation or cross-contamination
- Caution:** Do not use the accessory if you see signs of damage to the accessory packaging or to the accessory
- Caution:** When the device and its accessories have reached their end of life, they must be disposed of in accordance with the guidelines for handling of regulatory products and local regulations for contaminants and biohazards

7.1 Attachment List

- Caution:** This manual introduces this product according to the most complete configuration. The purchased product may not have some configurations or functions.

Material Coding	Name	Specification
38-000093-00	Isoflurane vaporizer Pour-fill	Isoflurane vaporizer Pour-fill
38-000135-00	Isoflurane vaporizer Key-Fill	Isoflurane vaporizer Key-Fill
38-000137-00	Isoflurane vaporizer Easy-Fill	Isoflurane vaporizer Easy-Fill
38-000139-00	Enflurane vaporizer Pour-Fill	Enflurane vaporizer Pour-Fill
38-000141-00	Enflurane vaporizer Key-Fill	Enflurane vaporizer Key-Fill
38-000143-00	Enflurane vaporizer Easy-Fill	Enflurane vaporizer Easy-Fill
38-000145-00	Sevoflurane vaporizer Pour-Fill	Sevoflurane vaporizer Pour-Fill
38-000147-00	Sevoflurane vaporizer Key-Fill	Sevoflurane vaporizer Key-Fill
38-000149-00	Sevoflurane vaporizer Easy-Fill	Sevoflurane vaporizer Easy-Fill
38-000151-00	Sevoflurane vaporizer Quik-Fil	Sevoflurane vaporizer Quik-Fil
38-000059-00	Oxygen gas source software 5 (GB)	One end of NIST joint, one end of pressure relief valve ball head (3m) GB blue
38-000061-00	Y-shaped breathing circuit	Y-shaped breathing circuit 15mm (children), 1.5M
37-000083-00	Exhaust gas recovery pipe	One end of 22 inner direct head, 22 inner right angle joint pipe (50cm retractable pipe)
38-000071-00	A set of breathing bag	3L/2L/1L/0.5L each
65-000005-00	Stand	Four caster with brakes
36-000079-00	Air source oxygen pressure reducing valve	YQY-12
38-000081-00	A set of tracheal intubation	2mm~10mm (17 specifications in

		total)
38-000067-00	Waste gas recovery tank	22 Outer cone joint recovery tank

A.0 Product Specification

A.1 Safety Specification

Anti-shock rating	BF Application Part
Inlet protection level	IPX1
Disinfection and sterilization method	Equipment with a method of disinfection and sterilization recommended by the manufacturer
Explosion protection class	No explosion protection (common equipment), no flammable anesthetics
Mobile level	Portable or mobile device (stand)

Table A-1 Safety Specification

A.2 Environment Specification

Anaesthesia Machine			
Term	temperature (°C)	Relative humidity (non-condensing)	Atmospheric pressure (kpa)
Working environment	10~40	15%~95%	70~106.7
Storage environment	-20~60	10%~95%	50~106.7

Table A-2 Environment Specification

A.3 Physical Specifications

Overall size	
Size	The volume of the whole machine (excluding stand, waste gas canister, including accessories), Length: 385mm Width: 405mm Height: 265mm The volume of the whole machine (excluding the waste gas canister, including the stand and accessories), Length: 1230 mm Width: 535mm Height:575 mm
Standard configuration weight	≤20kg,(not include stand , waste gas canister, accessories included) ≤34kg,(Excluding waste gas canister, including stand and accessories)
Maximum configuration weight	≤40kg,(Including stand, accessories, exhaust gas, waste gas canister, air source pressure reducing valve)
Casters	
Caster	4, all four casters with brakes

Table A-3 Physical Specifications

A.4 Air System Specifications

Gas source	
Gas type	Oxygen
Air source pressure range	280-600kpa/40-87psi
Interface Type	NIST/DISS
Flowmeter	
Flowmeter adjustment range	0-4L/min

Table A-4 Air System Specifications

A.5 Respiratory System Specifications

Port	
Manual bladder interface	Coaxial 22mm (OD)/15mm (ID) conical joint
Inspiratory Valve Port	Coaxial 22mm (OD)/15mm (ID) conical joint
Expiratory Valve Port	Coaxial 22mm (ODr)/15mm (ID) conical joint
Exhaust port	30mm outer conical joint
Airway pressure gauge	
Scope	-20cmH ₂ O~100cmH ₂ O
APL valve	
Scope	0~70cmH ₂ O

Table A-5 Respiratory System Specifications

A.6 Vaporizer

Vaporizer	
Vaporizer type (dosing method)	Isoflurane (Pour-Fill, Key-Fill, Easy-Fill) Enflurane (Pour-Fill, Key-Fill, Easy-Fill) Sevoflurane (Pour-Fill, Key-Fill, Easy-Fill, Quik-Fil)
Weight	Empty: 4kg ± 0.3kg Full drug state: 5kg ± 0.3kg
Capacity	core drying: 300ml~360ml core wetting: 240ml~300ml between maximum and minimum tick marks : 200ml~260ml
Concentration range	Isoflurane: 0-5vol,% Enflurane: 0-5vol,% Sevofluranes: 0-8vol,%
Concentration accuracy	± 0.25vol,% or ± 20% of the set value, whichever is greater

Table A-6 Anesthesia vaporizer

A.7 No Power AGSS

No power AGSS	
Port Type	30mm Conical joint (external)
Waste gas canister bracket	
Support configuration	The diameter of waste gas canister is not more than 80mm
Weight capacity	2kg

Table A-7 AGSS



TOOTOO MEDITECH CO., LTD.

Address: 3A, Phase II, Smart Home, No. 76, Baohe Avenue,
Baolong Community, Baolong Street, Longgang District,
Shenzhen, Guangdong, China

Tel: +86-755-28306385

Email: info@newtootoo.com

Web: www.newtootoo.com